

E

E12/E12-D **Manual 2.2 en**

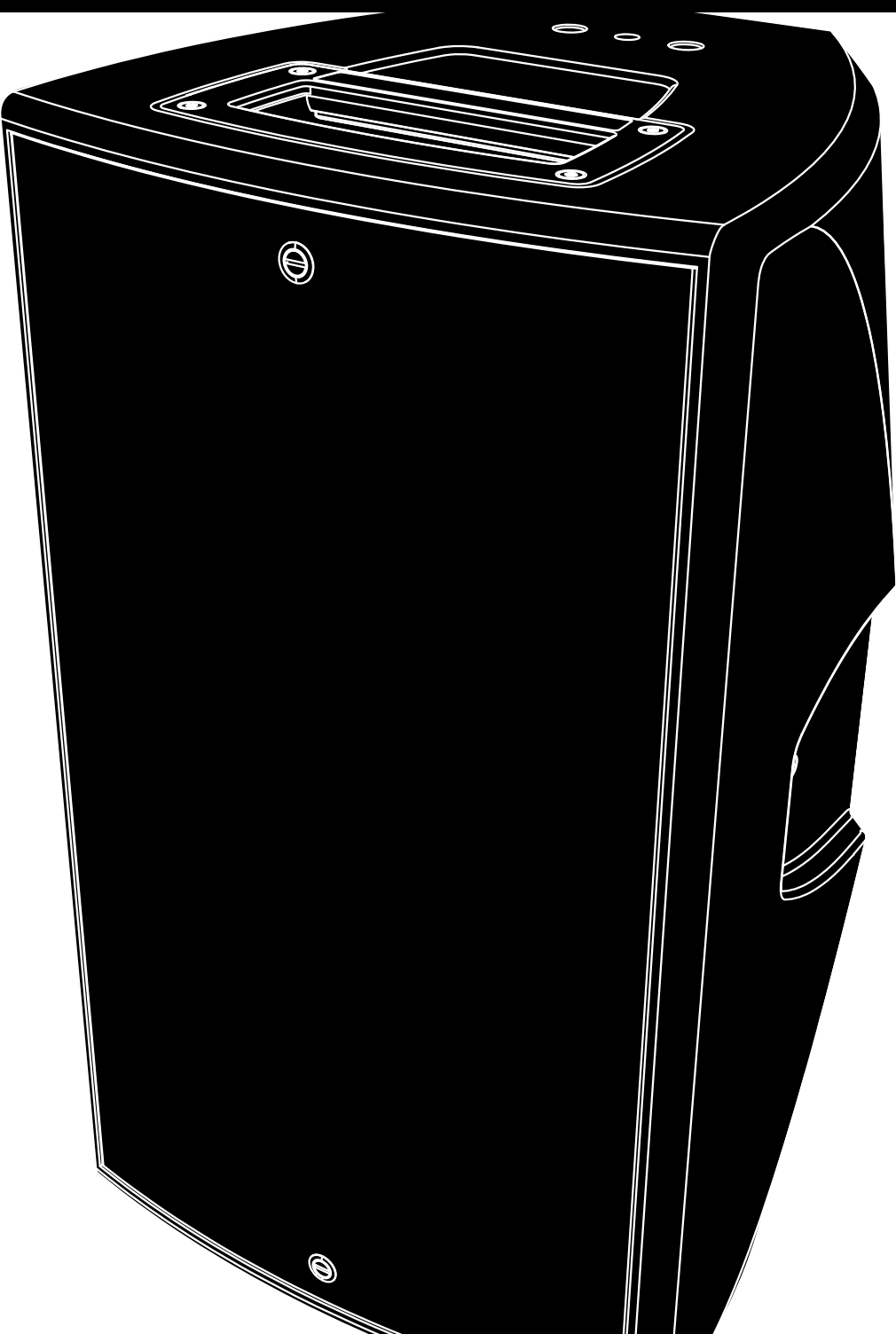

General information

E12/E12-D Manual

Version: 2.2 en, 10/2018, D2031.EN .02

Copyright © 2018 by d&b audiotechnik GmbH; all rights reserved.

Keep this document with the product or in a safe place so that it is available for future reference.

We recommend you to regularly check the d&b website for the latest version of this document.

When reselling this product, hand over this document to the new owner.

If you supply d&b products, please draw the attention of your customers to this document. Enclose the relevant documents with the systems. If you require additional documents for this purpose, you can order them from d&b.

d&b audiotechnik GmbH
Eugen-Adolf-Straße 134, D-71522 Backnang, Germany
T +49-7191-9669-0, F +49-7191-95 00 00

1	Safety precautions	4
1.1	Information regarding the use of loudspeakers.....	4
2	E12 loudspeaker	5
2.1	Product description.....	5
2.2	Connections.....	5
2.3	Operation.....	6
2.3.1	Controller settings.....	7
2.3.2	Operation with E-PAC.....	8
2.4	Dispersion characteristics.....	9
2.5	Technical specifications.....	11
3	Manufacturer's Declarations	13
3.1	EU conformity of loudspeakers (CE symbol).....	13
3.2	WEEE Declaration (Disposal).....	13

1.1 Information regarding the use of loudspeakers

Potential risk of personal injury

Never stand in the immediate vicinity of loudspeakers driven at a high level. Professional loudspeaker systems are capable of causing a sound pressure level detrimental to human health. Seemingly non-critical sound levels (from approx. 95 dB SPL) can cause hearing damage if people are exposed to it over a long period.

In order to prevent accidents when deploying loudspeakers on the ground or when flown, please take note of the following:

- When setting up the loudspeakers or loudspeaker stands, make sure they are standing on a firm surface. If you place several systems on top of one another, use straps to secure them against movement.
- Only use accessories which have been tested and approved by d&b for assembly and mobile deployment. Pay attention to the correct application and maximum load capacity of the accessories as detailed in our specific "Mounting instructions" or in our "Flying system and Rigging manuals".
- Ensure that all additional hardware, fixings and fasteners used for installation or mobile deployment are of an appropriate size and load safety factor. Pay attention to the manufacturers' instructions and to the relevant safety guidelines.
- Regularly check the loudspeaker housings and accessories for visible signs of wear and tear, and replace them when necessary.
- Regularly check all load bearing bolts in the mounting devices.

Potential risk of material damage

Loudspeakers produce a static magnetic field even if they are not connected or are not in use. Therefore make sure when erecting and transporting loudspeakers that they are nowhere near equipment and objects which may be impaired or damaged by an external magnetic field. Generally speaking, a distance of 0.5 m (1.5 ft) from magnetic data carriers (floppy disks, audio and video tapes, bank cards, etc.) is sufficient; a distance of more than 1 m (3 ft) may be necessary with computer and video monitors.

2 E12 loudspeaker

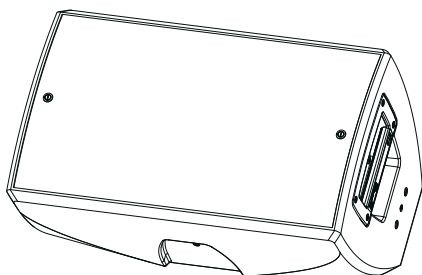
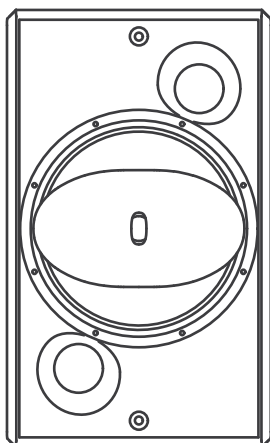

E12/E12-D loudspeaker and monitor position

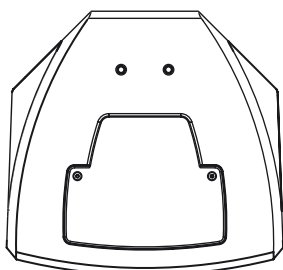

SC variants, top and bottom view

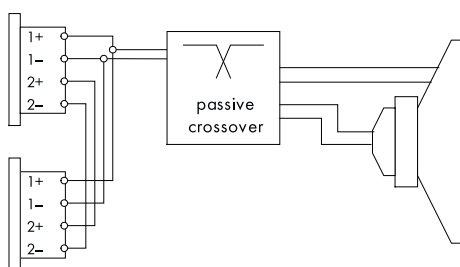

Connector wiring

2.1 Product description

The E12 and E12-D are high performance multipurpose loudspeakers employing an integrated 12"/1.3" exit coaxial driver design with neodymium magnet and constant directivity horn loading. It is available in two different dispersion versions, the E12 providing a 80° x 50° dispersion pattern (hor. x vert.), the E12-D a wider 110° x 50° pattern. Both horns can easily be rotated through 90° without the use of tools, providing 50° x 80° or 50° x 110° dispersion patterns.

The E12 is a two-way design with a built-in passive crossover network. Its frequency response extends from 50 Hz to 18 kHz.

The enclosures are constructed from polyurethane integral hard foam with an impact resistant paint finish. The cabinet shape allows use either in a vertical or horizontal orientation as well as deployment as a stage monitor. The front of the loudspeaker cabinets are protected by a rigid metal grill backed by an acoustically transparent foam.

The loudspeaker cabinets incorporate a pair of handles, a pole mount socket and six M10 threaded inserts to connect to different rigging accessories like Z5352 Flying bracket E12, Z5020 Flying adapter O2, Z5025 Flying adapter O3 or a Z5353 Horizontal bracket E12. An additional M10 thread in the rear panel can be used to connect a safety wire.

Cabinet options

The special color (SC) version of the cabinet is available in all colors of the RAL color table. It comes without high stand flange and handles. The respective openings of the cabinet are covered by plates in cabinet color. The connector type is NLT4.

2.2 Connections

The cabinets are fitted with NLT4 F/M connectors. All four pins of both connectors are wired in parallel. The cabinet uses the pin assignments 1+/1-. Pins 2+/2- are designated to actively driven subwoofers. Using one connector as the input, the second connector allows for direct connection to a second cabinet.

NLT4 F/M	1+	1-	2+	2-	-
EP5	1	2	3	4	5

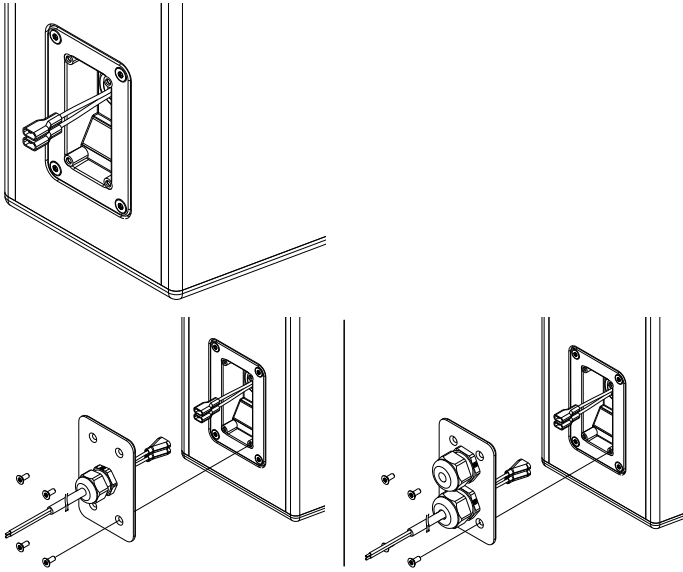

Faston type connector, male single PG (standard), dual PG (optional)

WR option (Weather Resistance)

A number of d&b loudspeakers are available in special options suitable for different types of installed applications and environmental conditions. The following options are available for the E12/E12-D loudspeaker:

- Weather resistant (WR): This option is suitable for outdoor use. The cabinets have an impact and weather protected black PCP (Polyurea Cabinet Protection) finish.
- Only for E12:
 - Sea water resistant (SWR): This option is suitable for outdoor use, especially in wet and acid or salty environments.

WR cabinets are equipped with a recessed connector panel including a Faston type connector (2 x 6.3 mm, female). A cover plate which accepts single or dual PG cable glands (Type PG13.5 for cable diameters from 6 - 12 mm) is enclosed, as shown in the graphic opposite.

NOTICE!

The WR option enables operation of loudspeakers in changing ambient conditions, however it is not intended to enable permanent, unprotected operation of loudspeakers outdoors.

- Provide an additional cover over the loudspeakers.
 - Aim the cabinets either horizontally or with a downward tilt.
-

To install the fixed connection cable, please proceed as follows:

Tools required: Screw driver (#T20).

Note: Observe the correct polarity of the cable
Brown (+) / Blue (-).

1. Insert the connection cable through the PG screwing and connect the male connector to the female connector.
2. Push the cover plate towards the connector panel until it fits into place.
3. Fix the cover plate to the connector panel using the four countersunk screws.

2.3 Operation

NOTICE!

Only operate d&b loudspeakers with a correctly configured d&b amplifier, otherwise there is a risk of damaging the loudspeaker components.

Applicable d&b amplifiers:

D80/D20/D12/D6/10D/30D.

Standard operation

Application	Setup	Cabinets per channel
E12	E12	2
E12-D	E12-D	2

For applicable d&b amplifiers, the controller setups are available in Dual Channel and/or Mix TOP/SUB mode. For combinations with active subwoofers fed by a single 4-wire cable Mix TOP/SUB mode must be selected.

Passive operation

Application	Setup	Combination per channel
E12 with E15X-SUB	E12-X	1
E12-D with E15X-SUB	E12-DX	1

In Dual Channel mode, the "X" setup can be selected to drive the cabinet in combination with the E15X subwoofer on the same channel.

The setup provides a dedicated correction for the combined frequency response of the system.

2.3.1 Controller settings

For acoustic adjustment the functions CUT, HFA and CPL can be selected.

CUT mode

Set to CUT, the low frequency level is reduced. The cabinet is now configured for use with actively driven d&b subwoofers.

HFA mode

In HFA mode (High Frequency Attenuation), the HF response of the system is rolled off. HFA provides a natural, balanced frequency response when a cabinet is placed close to listeners in near field or delay use.

High Frequency Attenuation begins gradually at 1 kHz, dropping by approximately 3 dB at 10 kHz. This roll off mimics the decline in frequency response experienced when listening to a system from a distance in a typically reverberant room or auditorium.

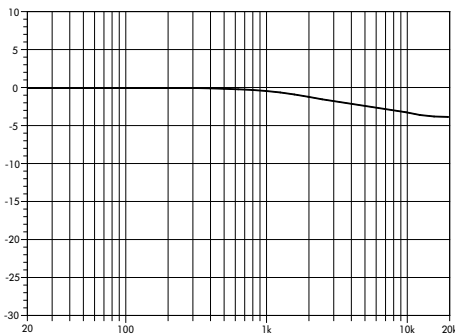

Frequency response correction in HFA mode

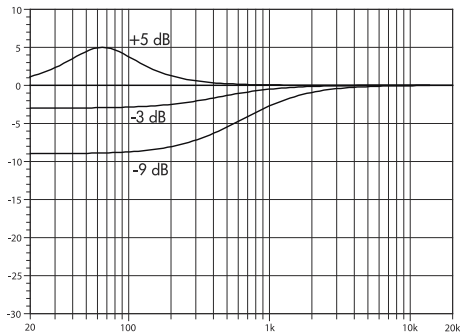

Frequency response correction of the CPL function

CPL function

The CPL (Coupling) function compensates for coupling effects between the cabinet and close boundary surfaces or when the cabinet is used as a stage monitor. CPL begins gradually around 1 kHz, with the maximum attenuation below 250 Hz. To achieve a balanced frequency response, the CPL function can be set to dB attenuation values between 0 and -9.

Positive CPL values create an adjustable low frequency boost (0 to +5 dB) and can be set when the system is used in full range mode without subwoofers.

2.3.2 Operation with E-PAC

Selecting E12 or E12-D mode enables the E-PAC to drive one E12 or E12-D loudspeaker. LO IMP mode configures the E-PAC to drive a maximum of two E12 or E12-D loudspeakers with a 6 dB reduction in input level to the loudspeakers.

For acoustic adjustment the CUT and HFA modes are available. The characteristics are described in the previous section.

2.4 Dispersion characteristics

The following graphs show dispersion angle over frequency of a single cabinet plotted using lines of equal sound pressure (isobars) at -6 dB and -12 dB.

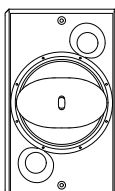
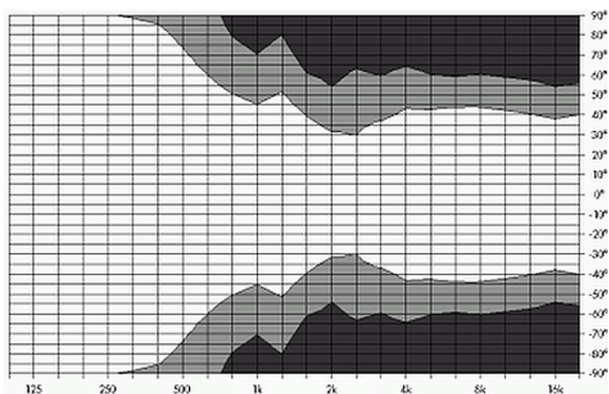

Isobar diagram E12 horizontal, standard setup

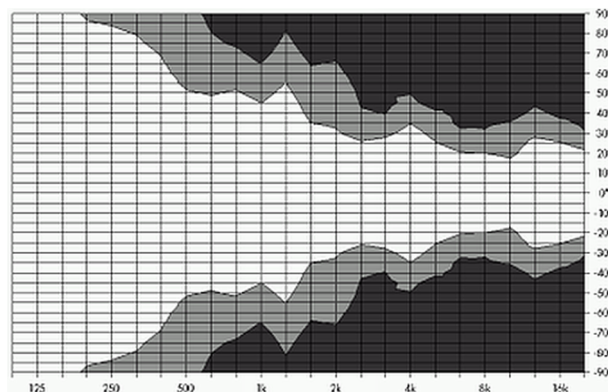

Isobar diagram E12 vertical, standard setup

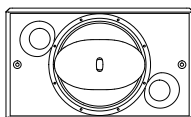
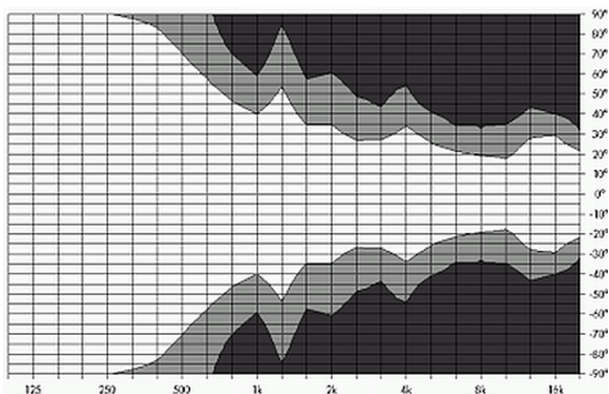

Isobar diagram E12 horizontal, horizontal setup with the horn rotated

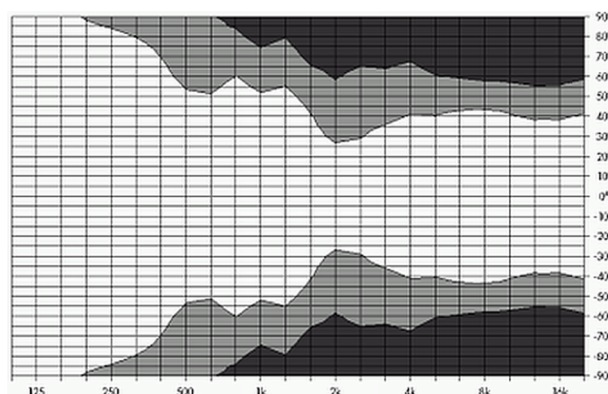

Isobar diagram E12 vertical, horizontal setup with the horn rotated

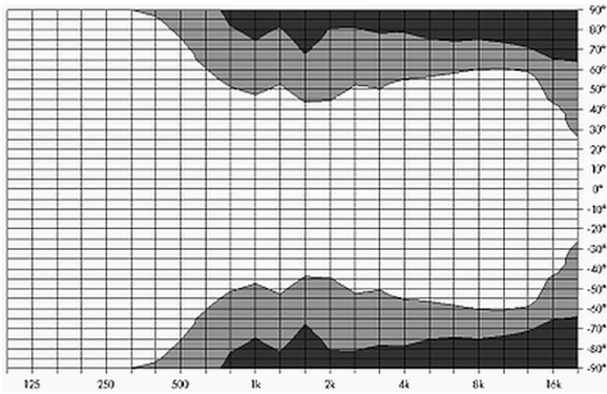

Isobar diagram E12-D horizontal, standard setup

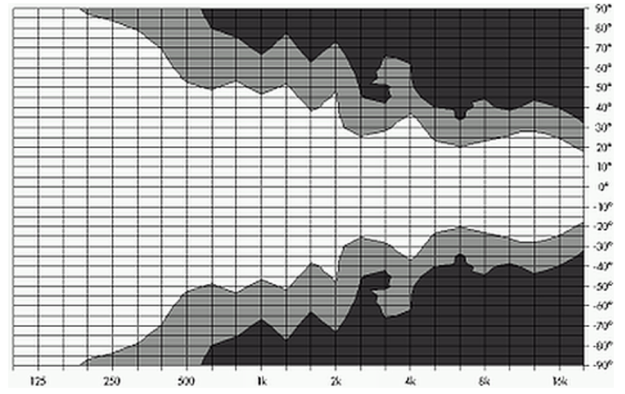

Isobar diagram E12-D vertical, standard setup

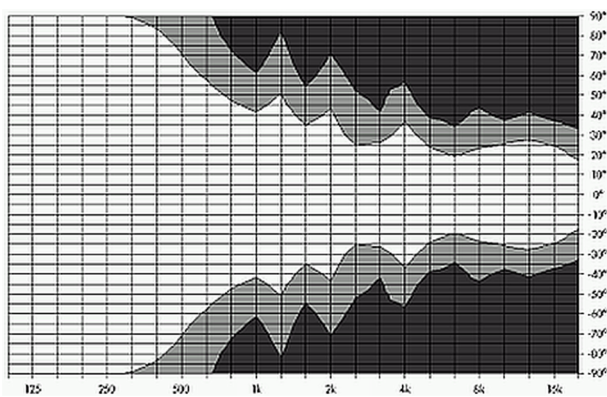

Isobar diagram E12-D horizontal, horizontal setup with the horn rotated

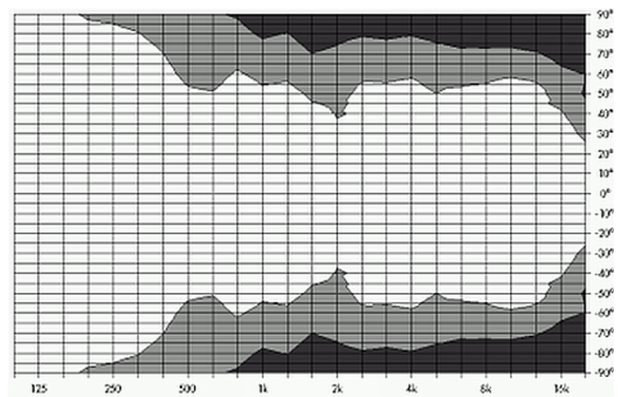

Isobar diagram E12-D vertical, horizontal setup with the horn rotated

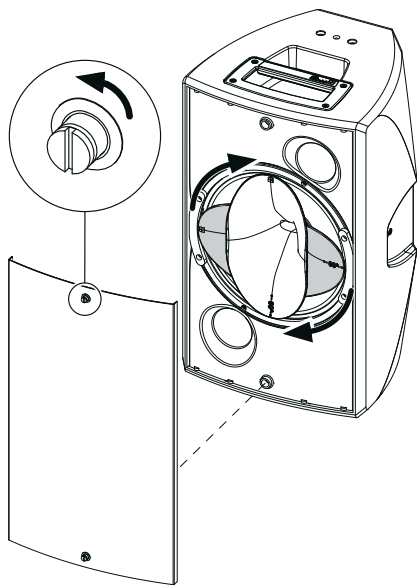

Rotating the horn

Altering the HF horn dispersion

The HF horn can be rotated through 90° within the coaxial driver assembly.



CAUTION!

Potential risk of personal injury due to falling objects.

- Set the correct horn orientation before suspending the cabinet.
- Do not remove the front grill while the cabinet is mounted or flown above the ground.

Tools required: screw driver or an appropriate coin.

1. Disconnect the loudspeaker.
2. Undo the quick locks at the top and bottom of the front grill and remove the grill.
3. Pick the horn at its outer edges and turn it until it snaps into the desired orientation.
4. Relocate and fix the front grill.
 - ↳ Make sure both quick locks of the front grill are locked correctly before using the loudspeaker.

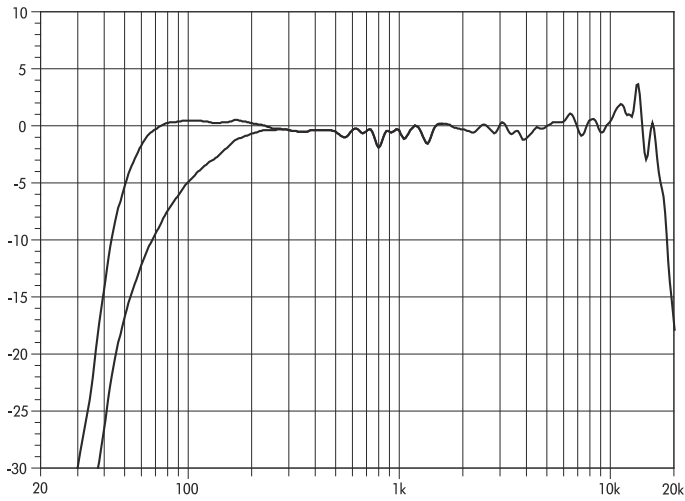

E12 frequency response, standard and CUT modes.

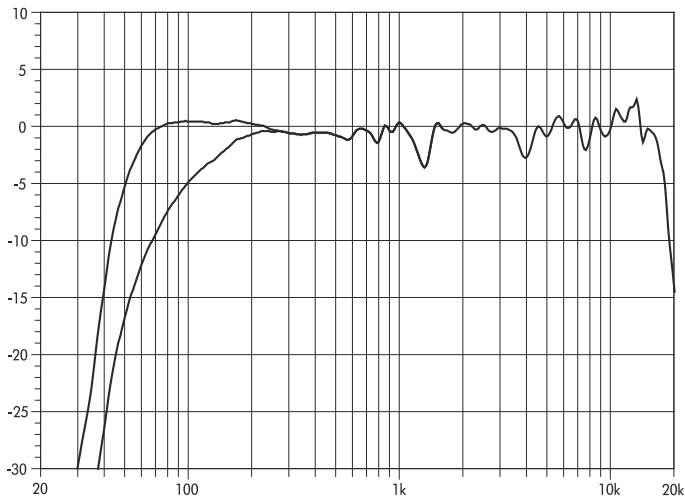

E12-D frequency response, standard and CUT modes.

2.5 Technical specifications

E12/E12-D system data

Frequency response (-5 dB standard mode)50 Hz - 18 kHz
Frequency response (-5 dB CUT mode) 100 Hz - 18 kHz
Max. sound pressure (1 m, free field)
with D6/10D/E-PAC 131/130 dB
with D12/D20/30D 134/133 dB
with D80 134/133 dB
 (SPLmax peak, pink noise test signal with crest factor 4)

E12/E12-D loudspeaker

Nominal impedance 8 ohms
Power handling capacity (RMS/peak 10 ms)300/1600 W
Nominal dispersion angle (hor. x vert.)80° x 50° (E12)
 110° x 50° (E12-D)
Components 12" driver with neodymium magnet
coaxial 1.3" exit compression driver with 3" coil and rotatable CD horn
 Passive crossover network
Connections NLT4 F/M
 Optional: 2 x EP5
 SC option: 2 x NL4 M
 WR option: Faston type connector (2 x 6.3mm)
Pin assignmentsNLT4 F/M: 1+/1-
 EP5: 1+/2-
 WR option: Brown + / Blue -
Weight 16 kg (35 lb)

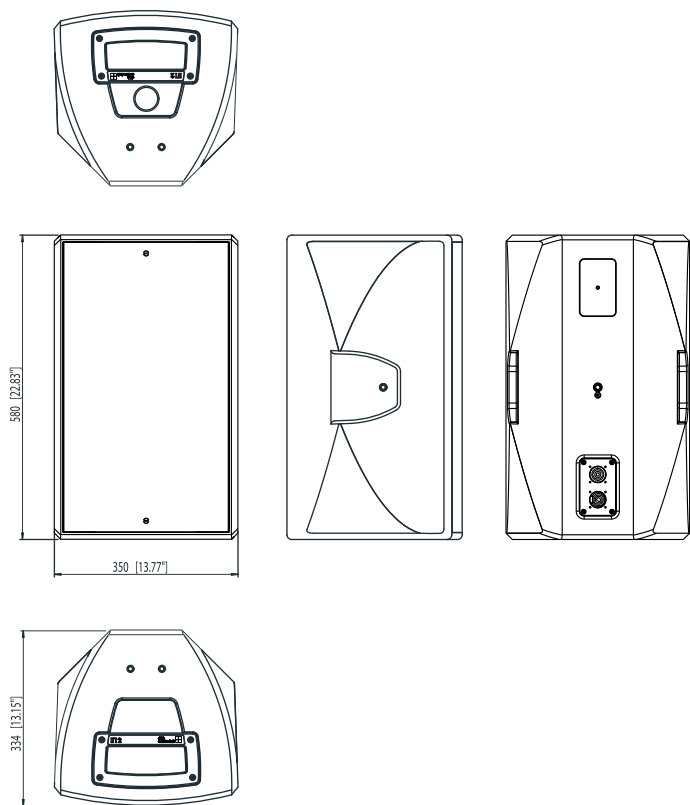

E12/E12-D cabinet dimensions in mm [inch]



3.1 EU conformity of loudspeakers (CE symbol)

This declaration applies to:

d&b E12 loudspeaker, Z0601

d&b E12-D loudspeaker, Z0602

manufactured by d&b audiotechnik GmbH.

All production versions of these types are included, provided they correspond to the original technical version and have not been subject to any later design or electromechanical modifications.

We herewith declare that said products are in conformity with the provisions of the respective EC directives including all applicable amendments.

A detailed declaration is available on request and can be ordered from d&b or downloaded from the d&b website at www.dbaudio.com.

3.2 WEEE Declaration (Disposal)

Electrical and electronic equipment must be disposed of separately from normal waste at the end of its operational lifetime.

Please dispose of this product according to the respective national regulations or contractual agreements. If there are any further questions concerning the disposal of this product, please contact d&b audiotechnik.



